



DS323: AI in Design (AIID)

Autumn 2023

Week 04 Lecture 08

Generative Design

Wan Fang

Southern University of Science and Technology

Design, AI & Robotics



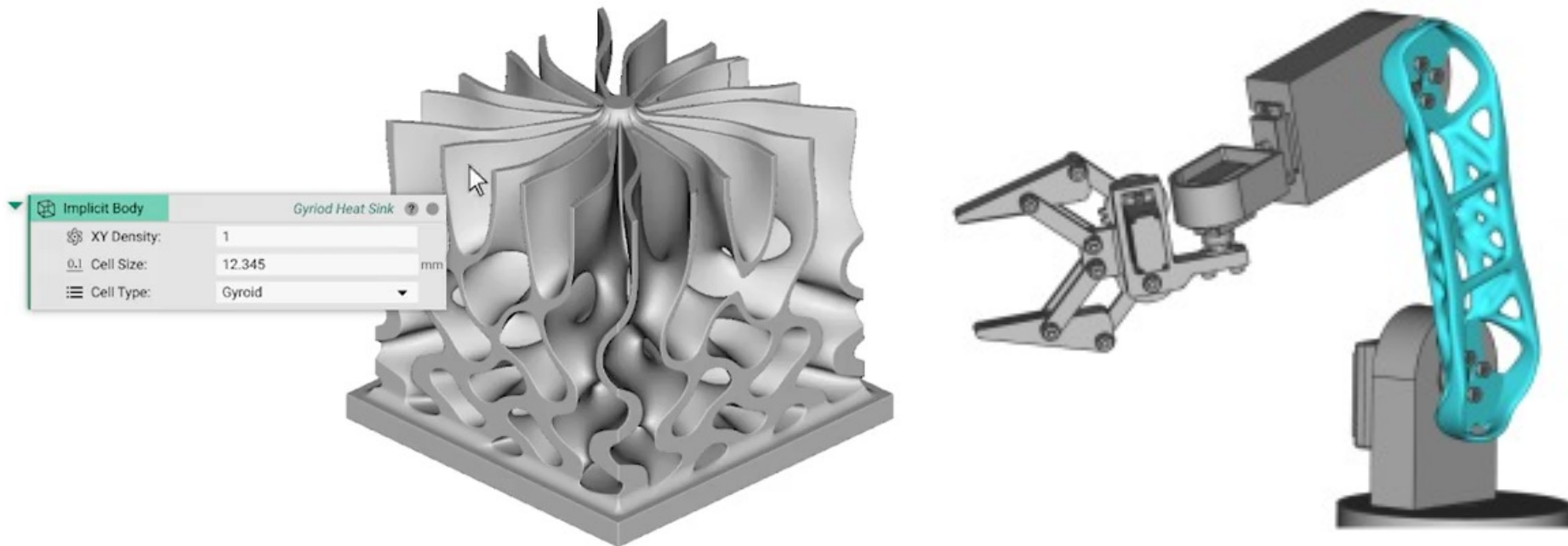

Generative Design

an advanced engineering methodology that combines geometry generation, simulation, and design automation

Introduction to Generative Design

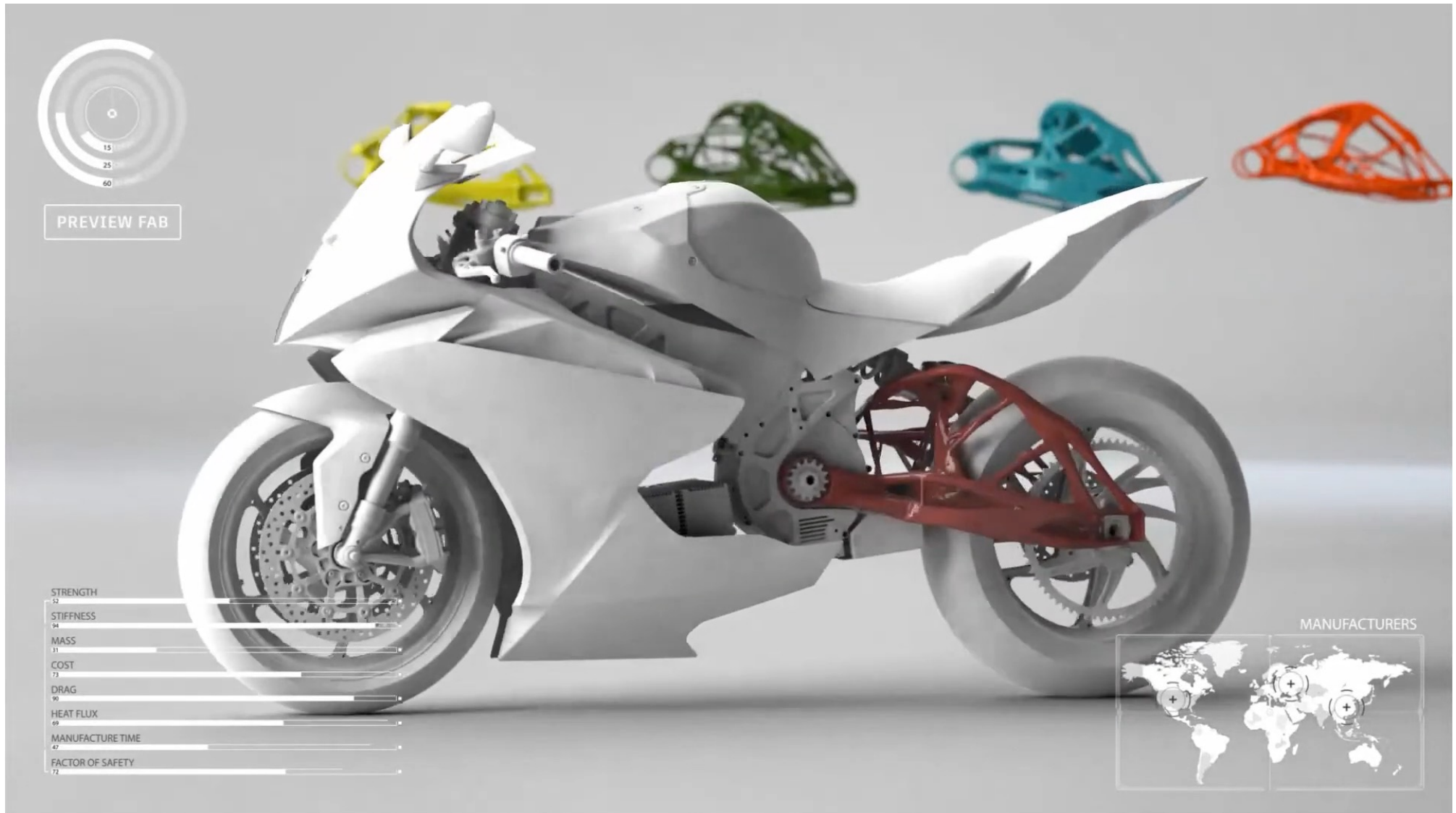

Computational Design

- Move with Perlin Noise
- Show cPts
- ShowXYZ
- Pyramids

- CtrlPointsX 3
- CtrlPointsY 8
- DegreeX 1
- DegreeY 2
- N Sides 6
- X Steps 10
- Y Steps 10

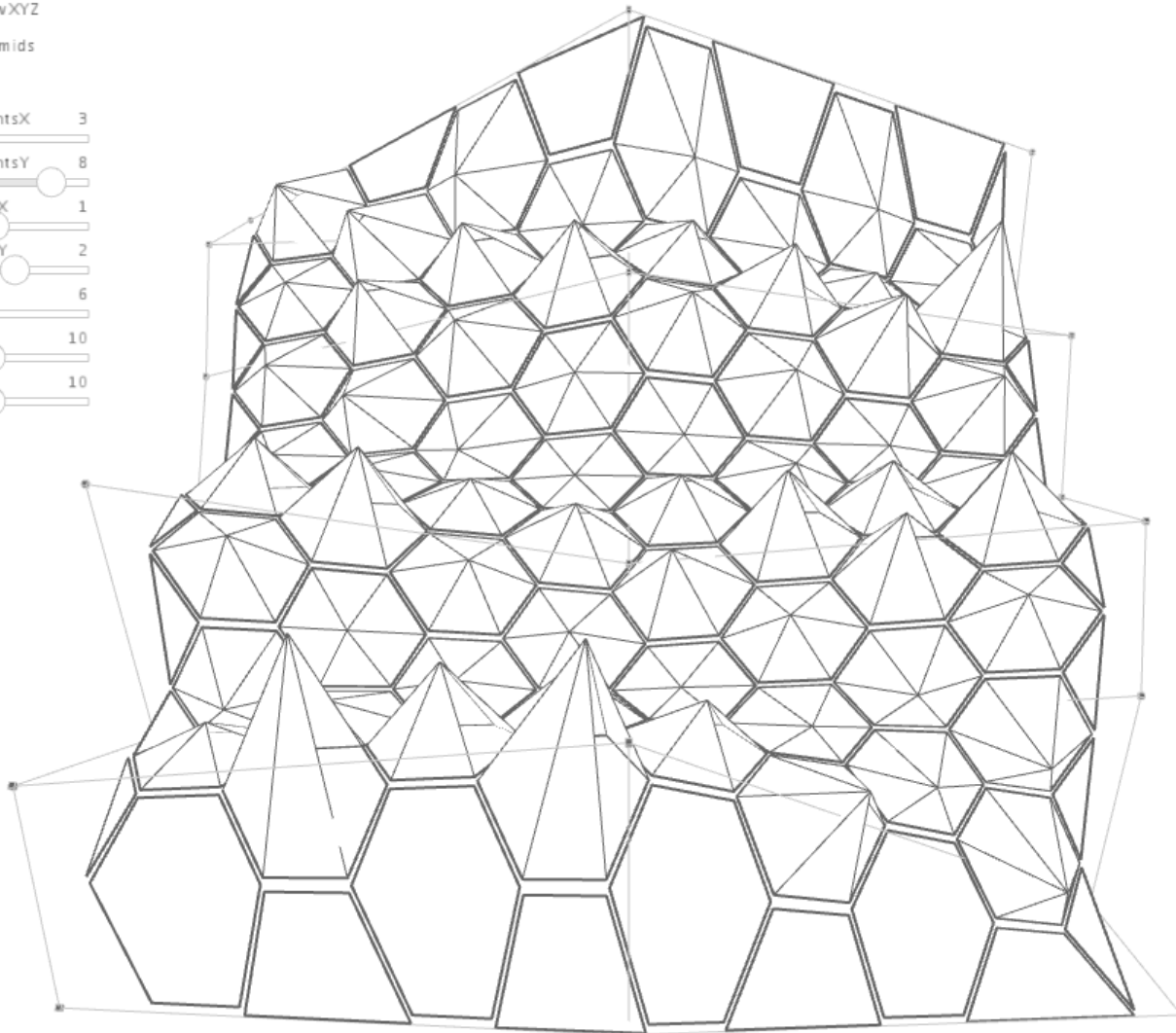

- Computational design is **NOT** any one algorithm or off-the-shelf process you can utilize.
- Rather, we describe it as an approach whereby **a designer defines a series of instructions, rules and relationships that precisely identify the steps necessary to achieve a proposed design and its resulting data or geometry.**
- Crucially, these steps must be **computable**, meaning they can be understood and calculated by a computer.

Image of an NURBS manipulations from Martin Stacey - UCL

Computational Design

- Move with Perlin Noise
- Show cPts
- ShowXYZ
- Pyramids

CtrlPointsX 3
CtrlPointsY 8
DegreeX 1
DegreeY 2
N Sides 6
X Steps 10
Y Steps 10

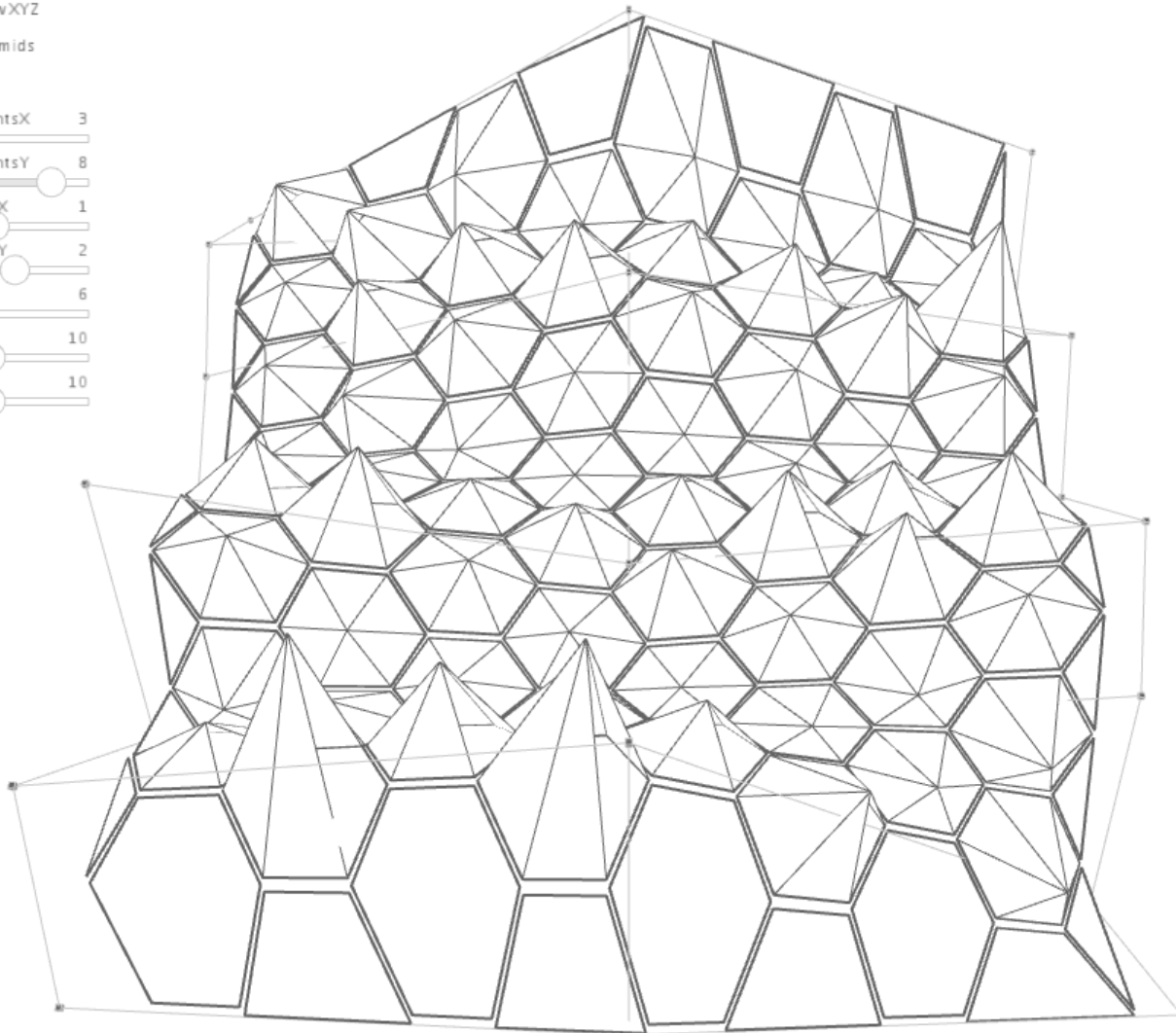
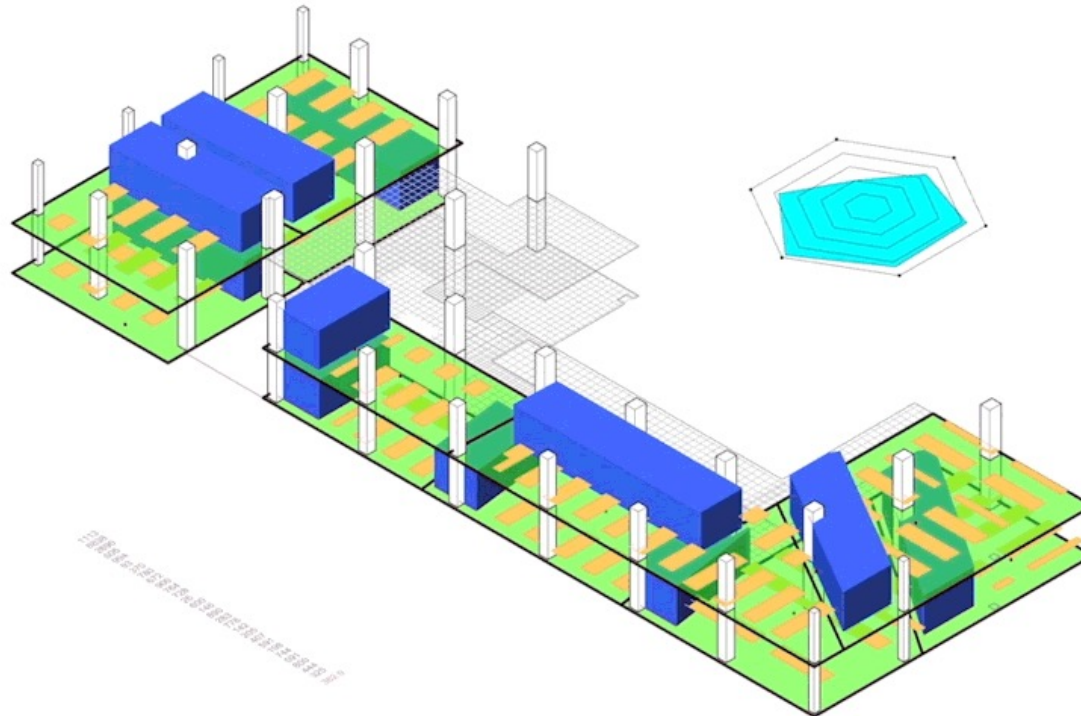

Image of an NURBS manipulations from Martin Stacey - UCL

- When approaching a design computationally, the designer would
 - **focus on developing the procedure that would create a design** - not the design itself.
- The process of iterating through options and data are **offloaded to a computer**.
 - Saves time, money and effort
 - Lets the designer focus on the creativity of the design process

What is Generative Design?

- A collaborative design process between humans and computers.
- During this process, the designer
 - **defines** the design parameters and the computer produces design studies (alternatives),
 - **evaluates** them against quantifiable goals set by the designer,
 - **improves** the studies by using results from previous ones and feedback from the designer, and
 - **ranks** the results based on how well they achieve the designer's original goals.



What is Generative Design?

- Generative design is a specific application of the computational design approach, with the following distinctions:
 - The designer defines goals to achieve a design (rather than the exact steps).
 - The computer helps the designer to explore the design space and generate multiple design options (not just one).
 - The computer enables the designer to find a set of optimal solutions that satisfy multiple competing goals.
 - The designer compares multiple design scenarios to find a set of design options that fits the design goals.

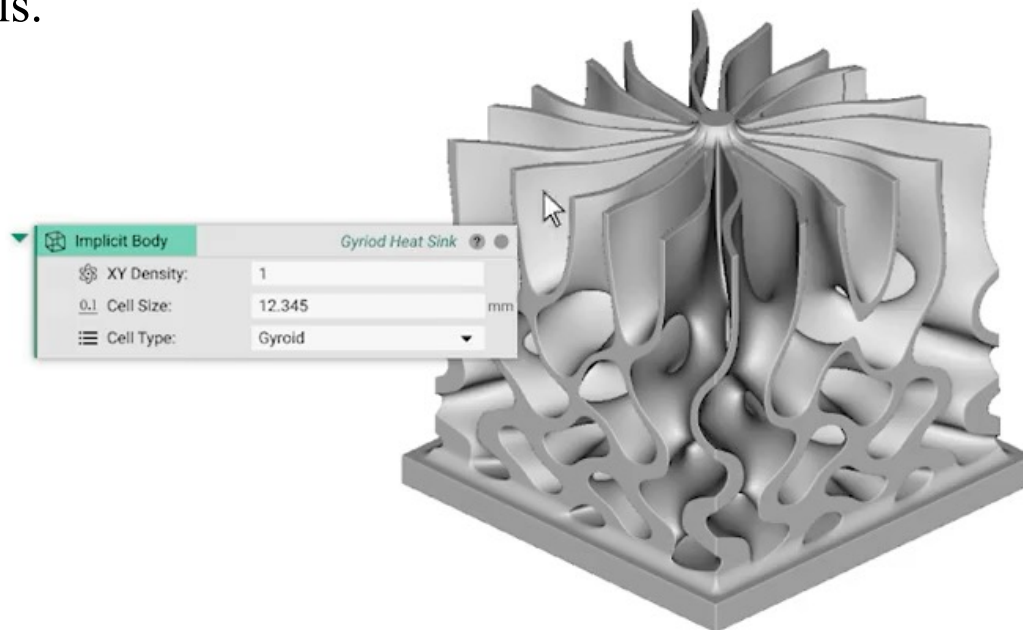

What is Generative Design?

- In a nutshell, generative design is a ***goal-driven approach*** to design that leverages automation so that designers and engineers can:
 - have better insight into their designs;
 - make faster, more informed design decisions; and
 - explore more options using the power of computers.

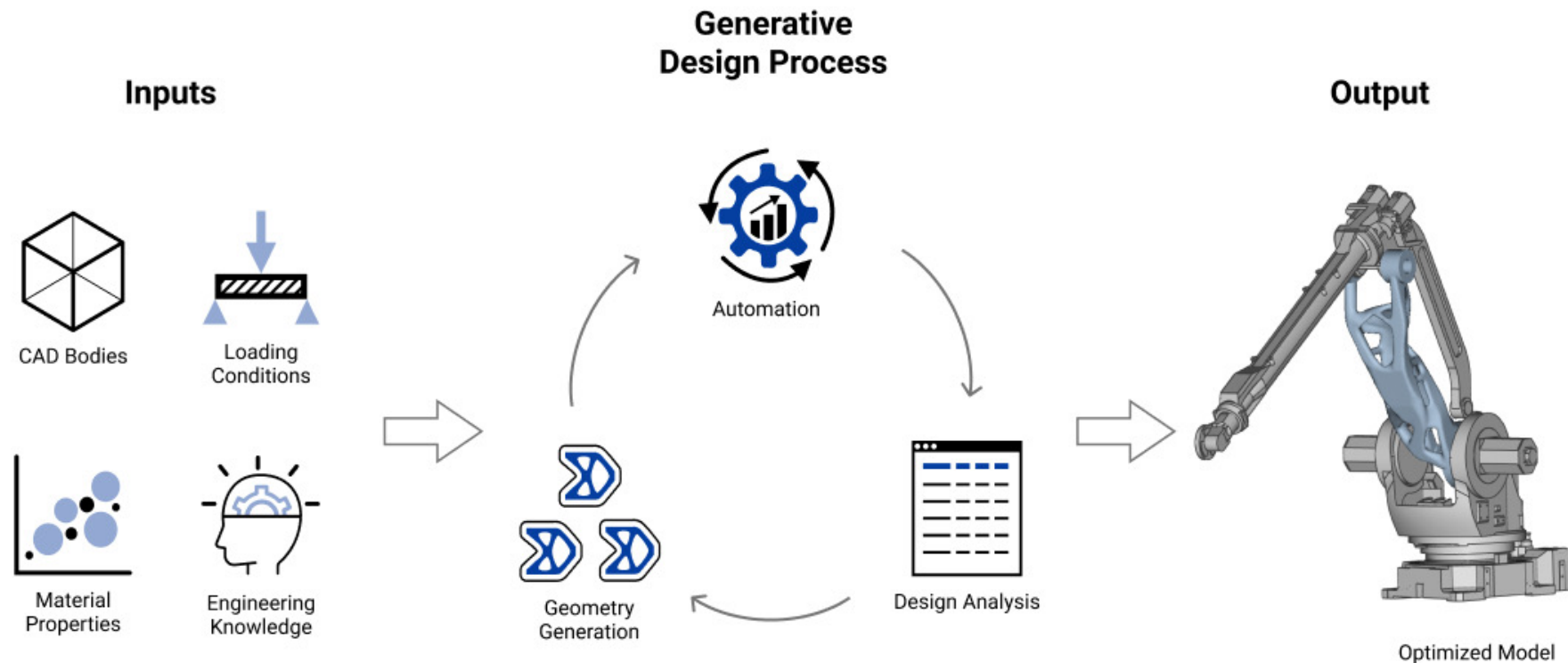

Why should I use Generative Design?

• Better Outcomes and Insight

- As the designer, you specify which outcomes you want to achieve for your design and how they are measured. With your guidance, the computer produces sets of optimal designs, along with the data used to prove which design performs best against your goals. By analyzing how the generated designs measure up against the set goals, you can gain valuable insight into which design aspects impact the outcome and how.

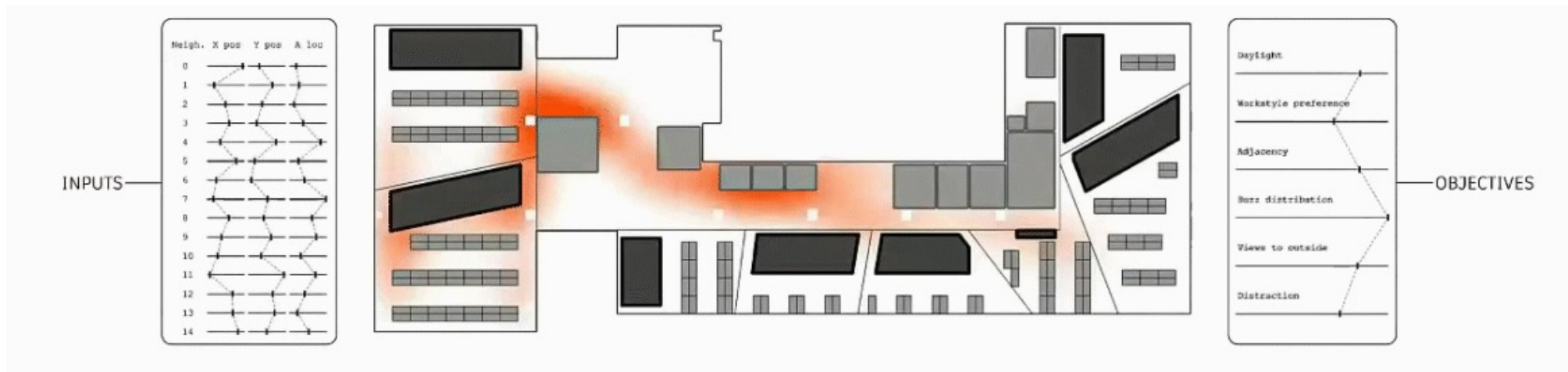

Why should I use Generative Design?

• Faster, More Informed Design Decisions

- Generative design can help you find better designs for your project more quickly by leveraging what computers are good at: computation and repetition.
- Computers can generate and evaluate a huge number of design variants in only a fraction of the time it would take an individual designer, allowing you to learn what does and doesn't work at an accelerated pace.

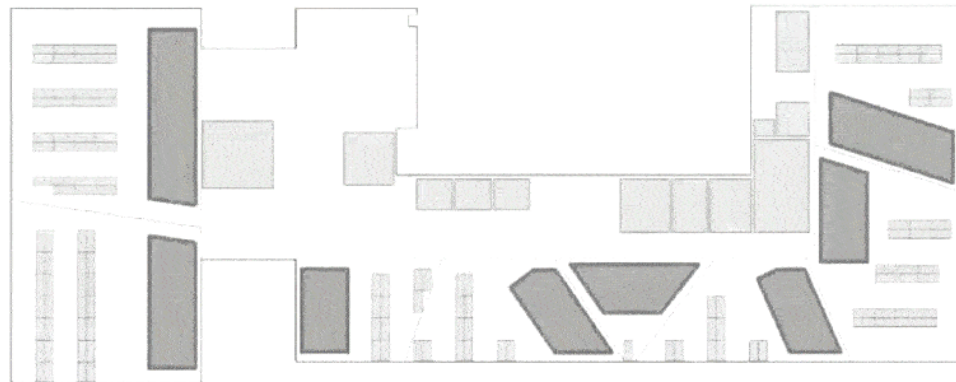

Design options generated - Mars Innovation District - The Living

Why should I use Generative Design?

• A Greater Variety of Options

- With a generative design approach, the initial design parameters you input are used to generate your potential design solutions, with the only limitation being how much computer power and time you have.
- For example, using traditional computational design techniques, it's feasible for you to explore ten variants (or more, perhaps). However, using generative design, an algorithm can generate thousands of variants in mere minutes.

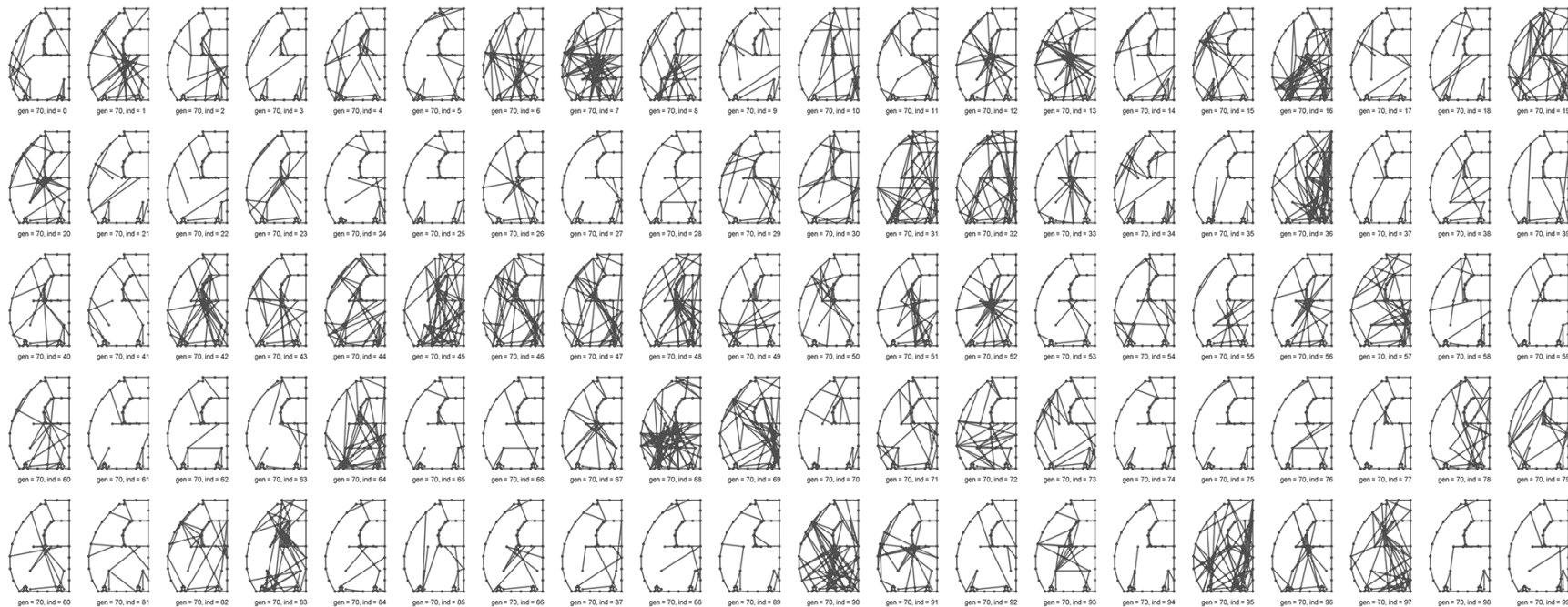

A Short History of Generative Design

'70s

- Generative Design has been the holy grail of CAD and CAE since their inception. **The earliest mentions in the late '70s focused on shipbuilding and architecture.**

'80s

- With the proliferation of CAD in the '80s, the interest in generative design increased. The results were still **limited by the computing power of the time.**

'90s & '00s

- In the '90s and early '00s, simulation-driven design, such as **topology optimization**, started to gain traction. The first structural optimization software hit the market.

'10s

- In the '10s, advancements in digital and additive manufacturing pushed companies to **accelerate the development** of commercial generative design solutions.

Today

- Generative design **finds applications beyond structural optimization**, enabled by the increased computational power and advanced engineering design software.

What goes into a Generative Design Process?

- A generative design approach allows for a more integrated workflow between human and computer

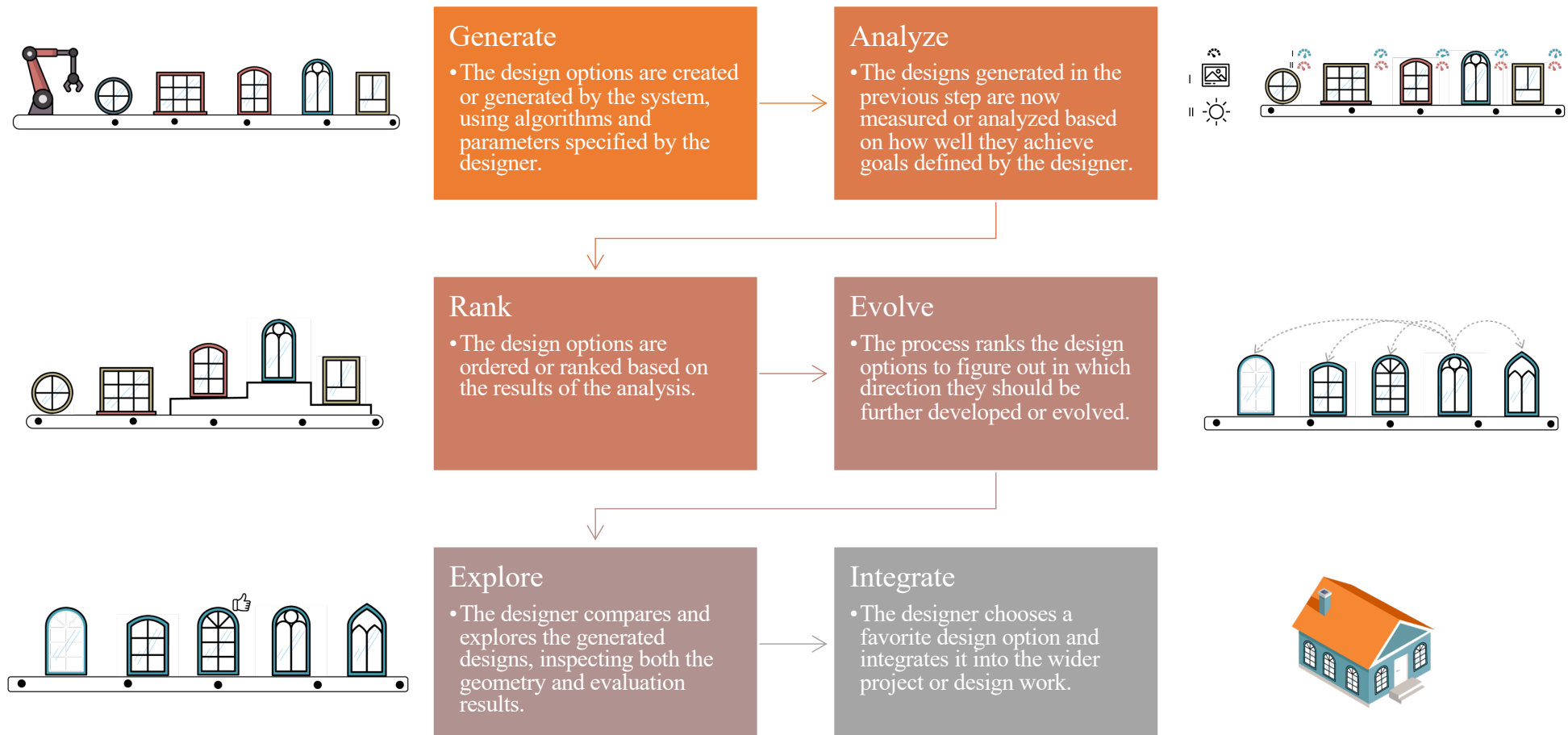

Anatomy of Each Stage

- Each of these stages can be further broken down into define, run and results steps.
 - The *define* step is the responsibility of the designer,
 - while the *run* and *results* steps are performed by the computer.
- Take the **Generate Stage** for example

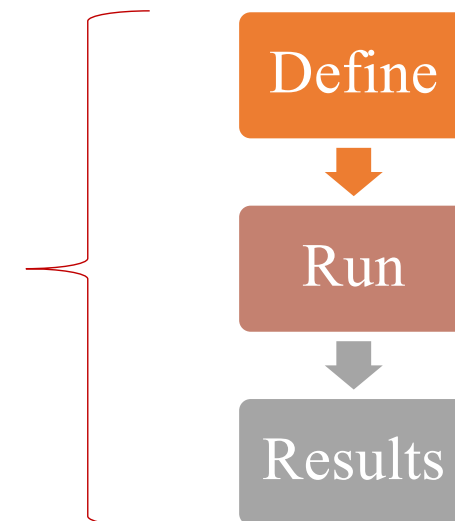
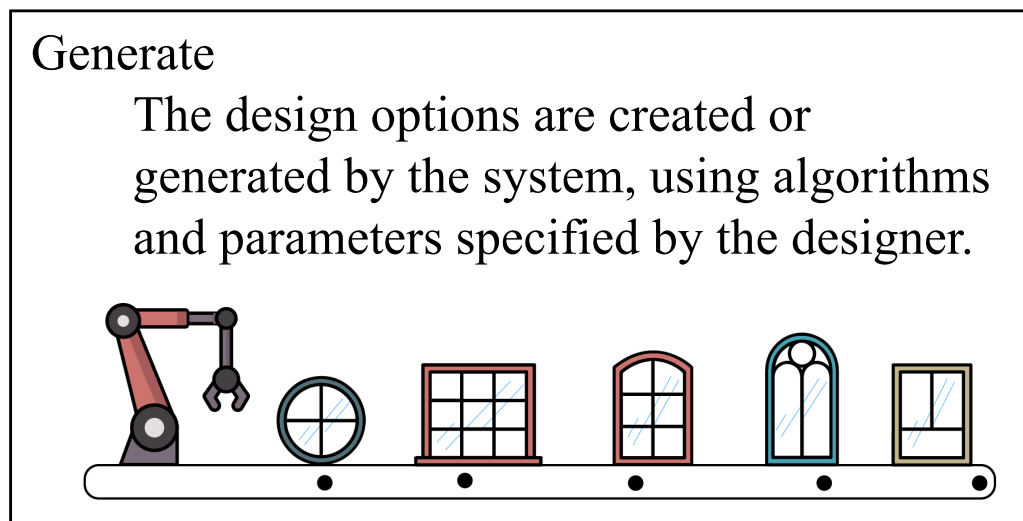

Anatomy of Each Stage: Define

- For the define step, the designer will need to do the following:
 - Establish the generation algorithm - this is the logic that defines how designs are generated, which may include things like constraints and rules.
 - Provide the generation parameters - these are the variables or inputs needed for the previously-defined algorithm.

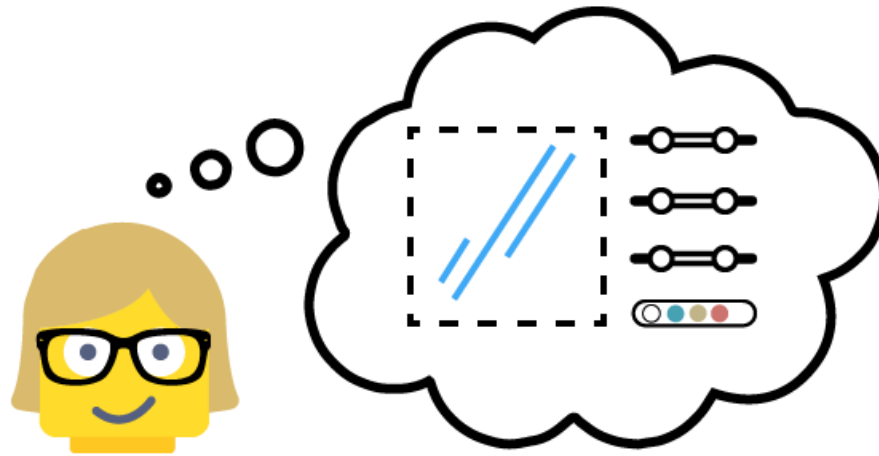

- This define step is present and vital for all stages of the generative design process, as the validity of outputs relies on the quality of the designer's contribution in this step.
- With clear and concise logic, the computer can provide suitable outputs.

Anatomy of Each Stage: Run & Results

- Run

- Once everything is defined in the algorithm and its accompanying parameters, the computer begins to run, meaning it starts to generate different design options.
- This process might happen locally on the designer's computer or, for more intensive calculations, it may happen using cloud computing.

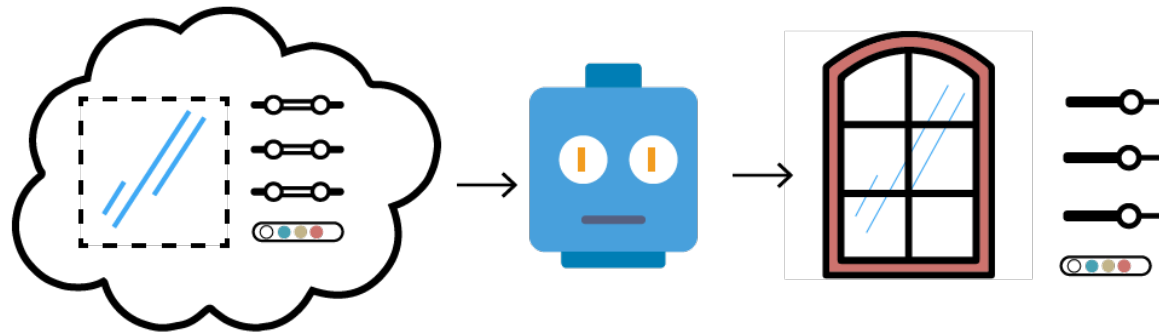

- Results

- The things that are generated during the run step are the final outputs from each stage. These are then used as inputs or parameters in subsequent phases.
- For example, the designs created in the generate phase will be used as one of input parameters in the analysis phase.

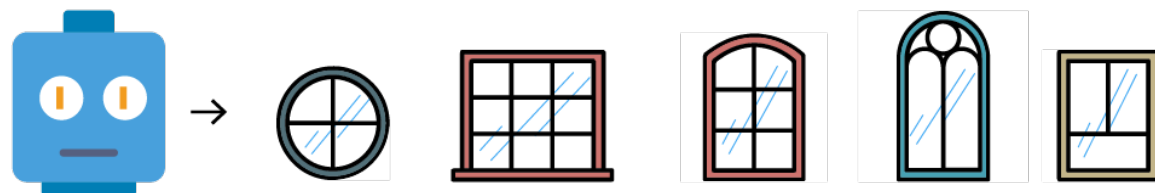

Overall Process

- The diagram shows
 - Each stage and step is **dependent** on the previous one.
 - The entire study process is **repeatable**, as each iteration learns from the previous results.

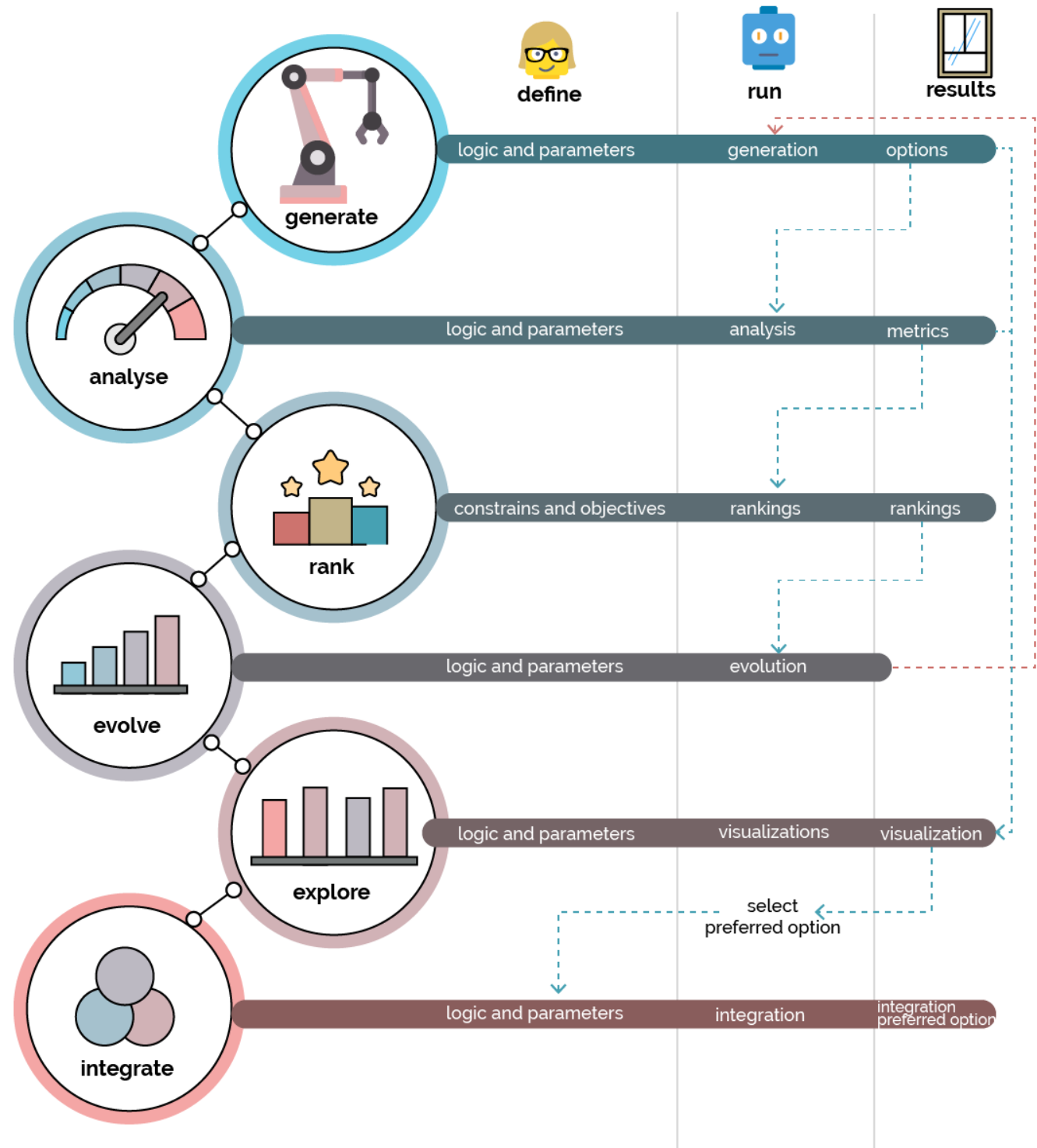

Generative Design & Additive Manufacturing

- Generative design enables the development of high-performance 3D printed products and is a near-necessity for any DfAM workflow.

DfAM = Design for Additive Manufacturing

One of the key benefits of industrial 3D printing is that it gives engineers the ability to manufacture **highly complex** and **high-performance parts** that are either impossible or prohibitively expensive to produce using traditional techniques.

However, modeling these complex and optimized geometries manually in traditional CAD software is **a near-impossible task**. The digital toolset of generative design enables engineers to manage the complexity of additive manufacturing and use it to their advantage.

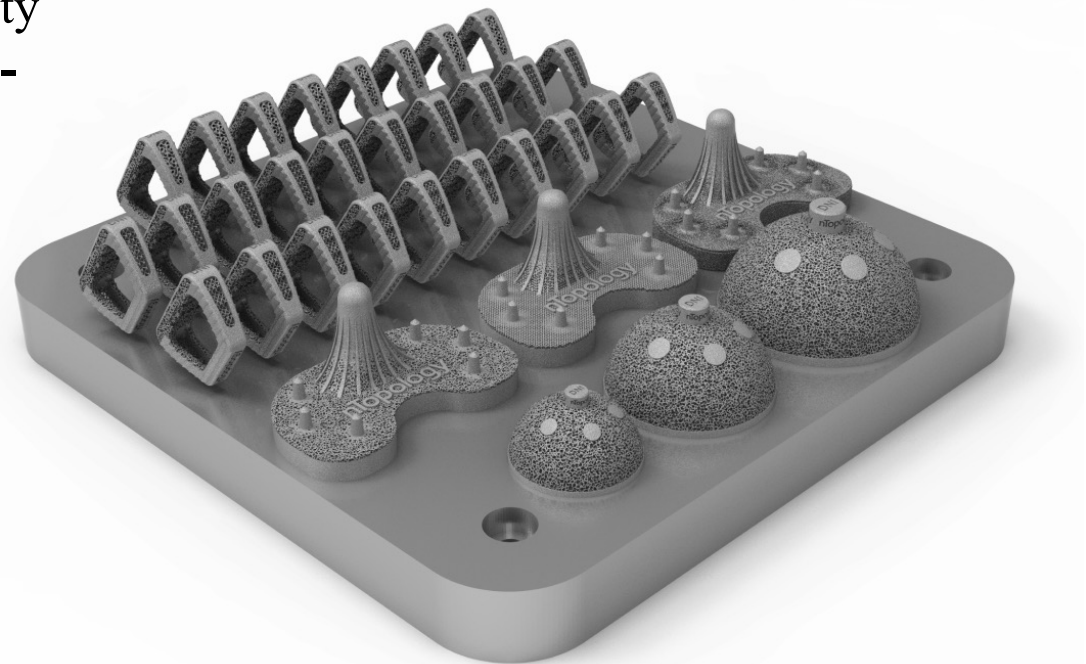

Benefits & Limitations

Benefits of Generative Design

High-performing products –

The digital capabilities of generative design can unlock a previously inaccessible design space. Using tools such as topology optimization, advanced lattice structures, and field-driven design, you can build lighter, higher-performing parts with increased functionality. Generative design has applications in every field of product development; from improving thermal management in electronic devices to developing more efficient rocket propulsion systems to reduce the cost of shooting payload into orbit.

Faster time to market –

Generative design accelerates all stages of product development, from concept design to manufacturing. Using its digital tools, engineers can quickly generate geometries with high complexity, from organic, freeflow parts to repetitive patterns with millions of elements. Since manufacturability can be taken into account early in the design process, the probability that time-consuming revisions are needed later on is much lower.

Unbiased engineering solutions –

While designing new products, engineers tend to draw inspiration from their past projects and experiences. While this is exceptionally valuable, an algorithmic approach (such as a well-designed generative process) can produce unbiased results that may contradict preconceived notions. Combining these results with the engineer's experience leads to faster and more radical product innovation.

Limitations of Generative Design

(Potentially) Non-transparent workflows –

Engineers frequently need to know just as much about the process as the resulting solution. Due to the complexity of generative algorithms, many software solutions operate using a “black box” approach. The engineer gives inputs and then is asked to evaluate the outputs without having visibility or control over the process that was followed in the backend. For mission-critical applications where design outputs must produce repeatable and reproducible results, this significantly hinders the adoption of specific generative design implementations.

Limited range of optimization requirements –

When performing generative design, it is essential to remember that your solution is only as accurate as the simulations used to produce it. Many physical phenomena aren't supported by most generative design software. This means that the result is optimized only for the limited set of design requirements that the software can handle. It is crucial to recognize that there are often many design requirements that may have not been taken into account during optimization.

Output quality depends on input quality –

Generative design still relies on the quality of information that an engineer can supply. Generative Design has two main input components: the design space and the loading conditions. To get optimized output, both the problem and the inputs need to be defined accurately. It is the job of the engineer to define the input parameters and the goal. For this reason, you should think of generative design as a collaborative process between the engineer and the design software.

Examples of Generative Design

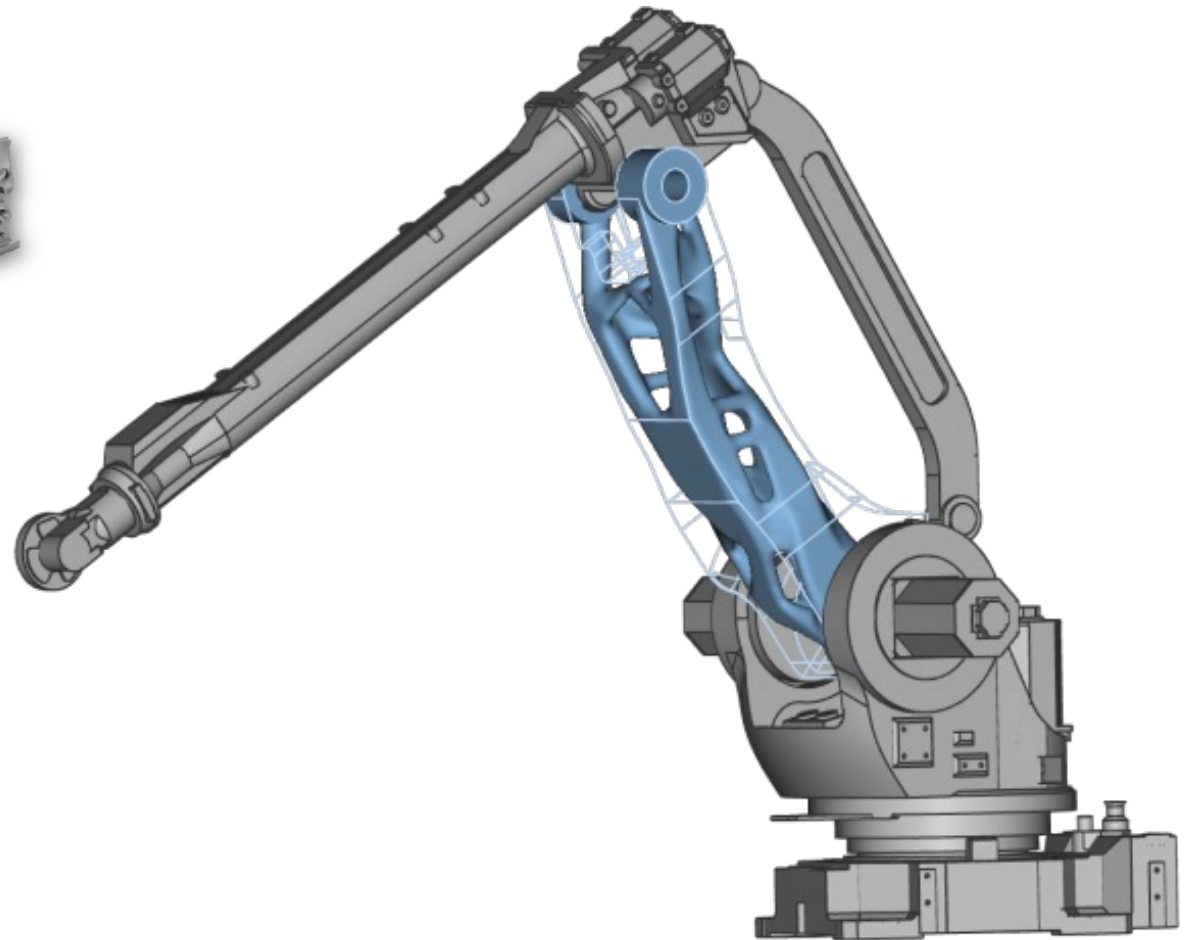
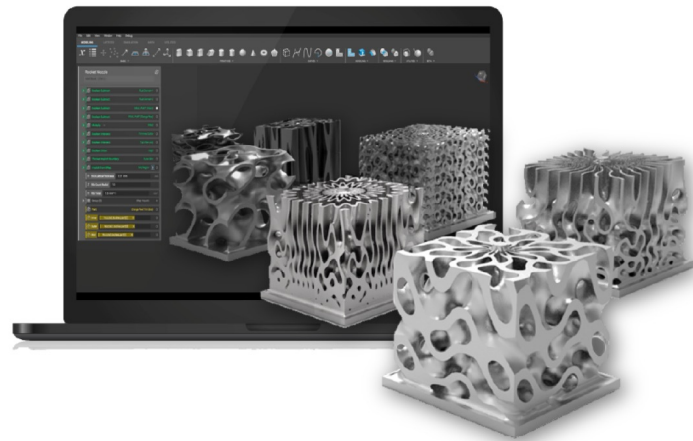

VW's Mini Van



Applications of Generative Design

Aerospace

Aerospace companies are applying generative design to shape tomorrow's greener, lighter and more efficient aircrafts, rockets, satellites and drones.

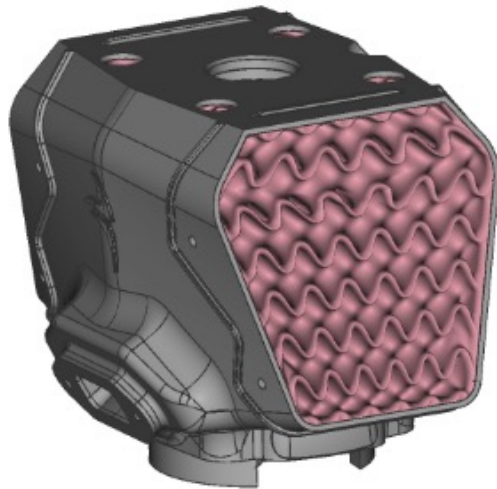

EXAMPLE APPLICATIONS

Heat Exchangers, Hydraulic and Pneumatic Systems, Landing Gear, Doors, Fuselage, Nacelles & Pylons

Automotive

With objectives centered around weight reduction, safety, and style, the automotive industry is already using generative design to develop parts for both performance and aesthetics.

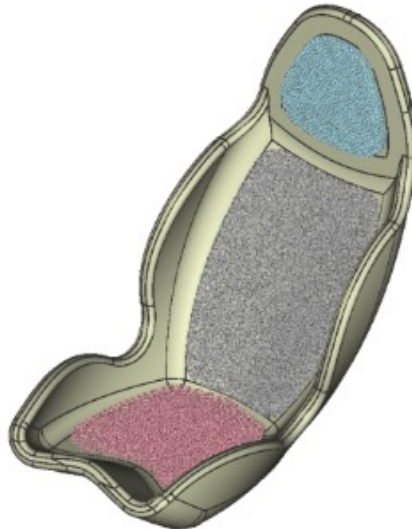

EXAMPLE APPLICATIONS

Uprights, Brake Caliper, Hydraulic Manifold, Seat Cushioning, Car Grilles, Customized Accessories

Manufacturing

Lightweighting and design automation, can enhance the efficiency any manufacturing process, from jigs & fixtures for large-scale assembly lines to customized 3D prints.



EXAMPLE APPLICATIONS

Jigs & Fixtures, Molds & Dies, AM Build Preparation, Robotic End of Arm Tooling

Applications of Generative Design

Medical Devices

With automated design analysis and geometry generation, biomedical engineers can design a wide variety of patient-specific medical devices with unrivaled speed and customization options.

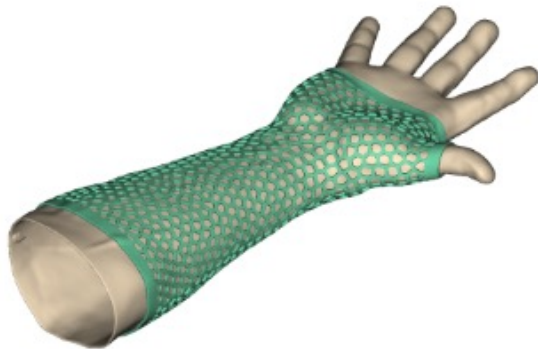

EXAMPLE APPLICATIONS

Orthopedic Implants, Prostheses, Orthotics, Casts, Dental implants

Consumer Products

Generative design software gives engineers the ability to generate manufacturing-ready design candidates, saving valuable design time and giving you a differentiation advantage.



EXAMPLE APPLICATIONS

Sports Equipment, Luxury Products, Footwear, Protective Gear

Heavy Industry

Weight reduction of heavy machinery through generative design enables engineers to minimize cost, improve safety and reduce energy consumption during both assembly and operation.



EXAMPLE APPLICATIONS

Trucks, industrial machinery, large metal casts, and forgings

Autodesk Generative Design

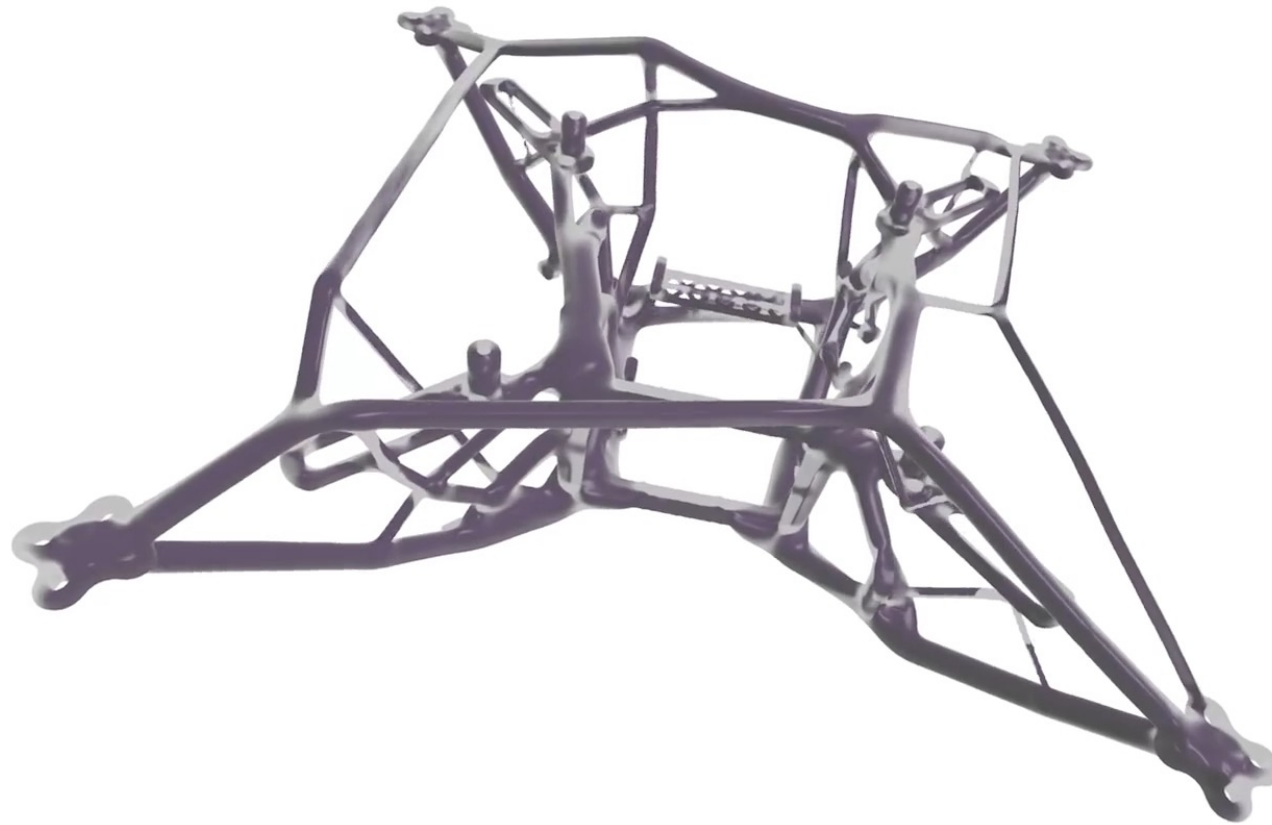

Generative Design NASA's Lander

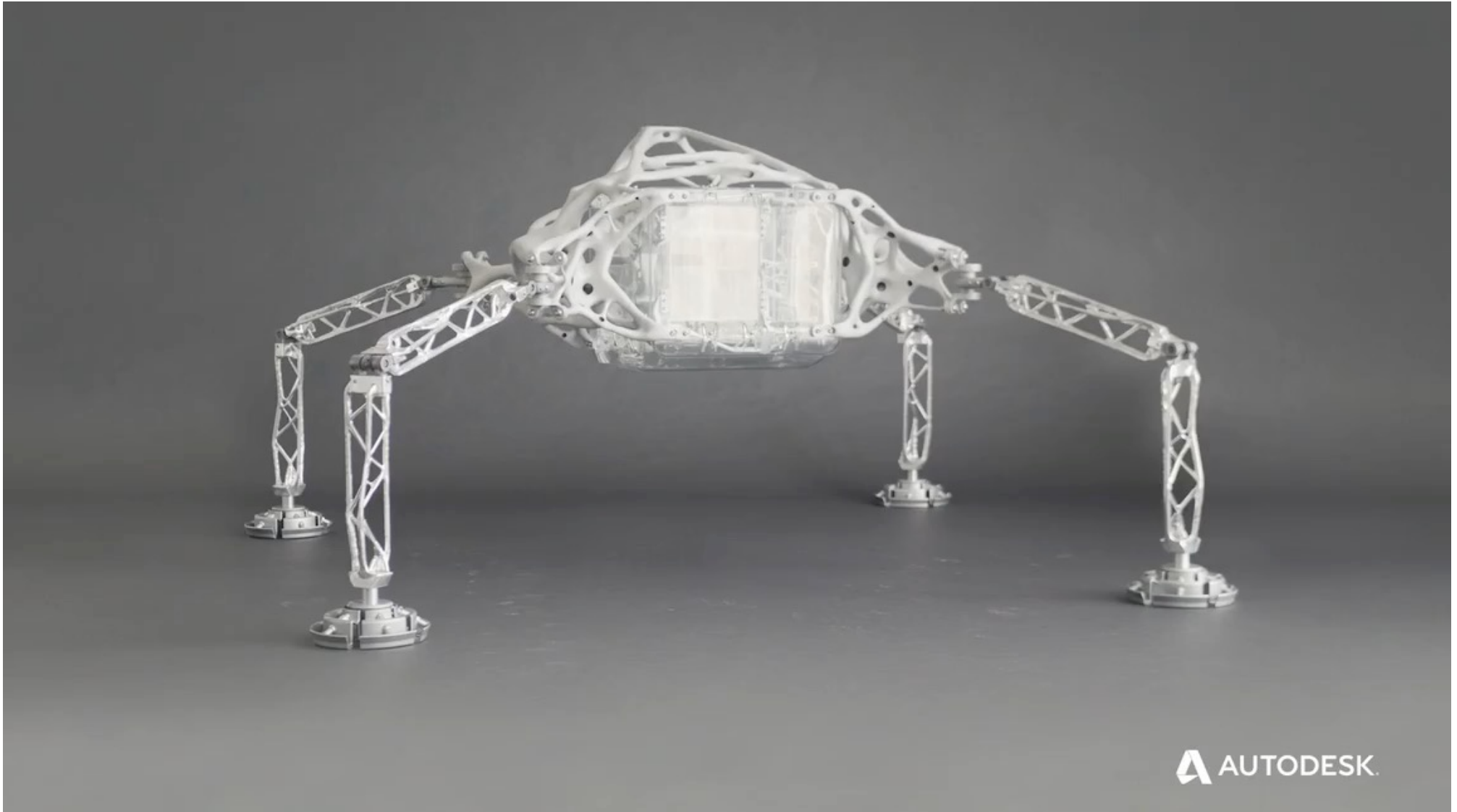

Roboy 2.0

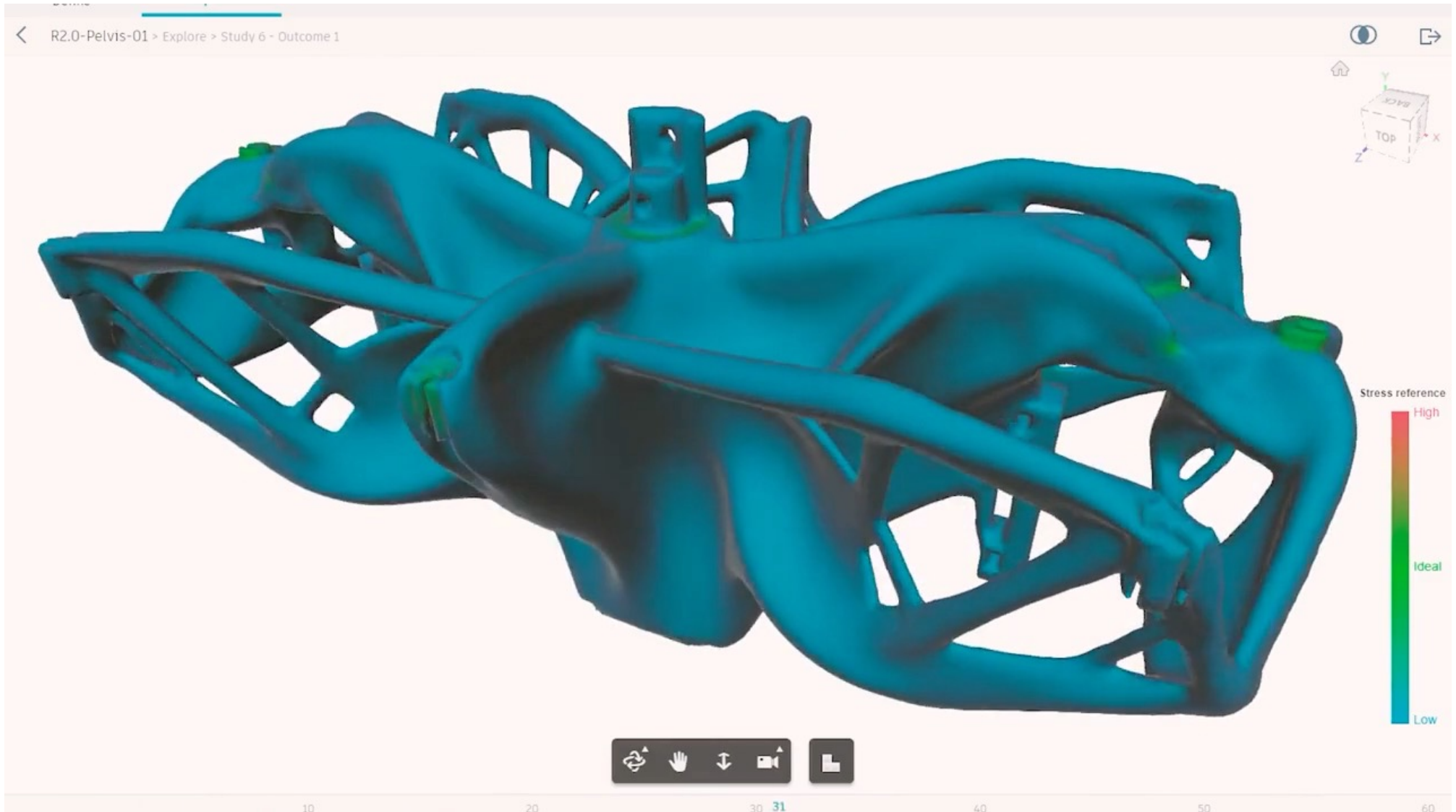

Roboy 3.0

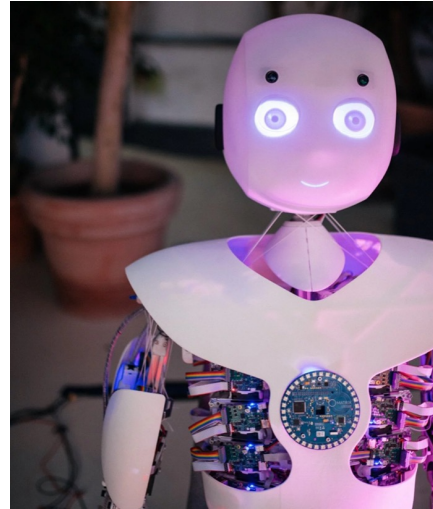

A.I. Chair by Philippe Starck



Called A.I., the chair was designed using prototype generative design software by Autodesk...

A.I. Chair by Philippe Starck



A.I. Chair by Philippe Starck

- Philippe Starck is a French industrial architect and designer known for his wide range of designs, including interior design, architecture, household objects, furniture, boats and other vehicles.

--Wikipedia

- *... design has no future, because matter has no future. we enter now the era of dematerialization and bionism, that is to say the alliance of the body with integrated high technology. in the upcoming years, all the useless things around us will disappear, they will directly integrate our environment and our body ...*

--philippe starck.



Fusion 360 Generative Design Technology

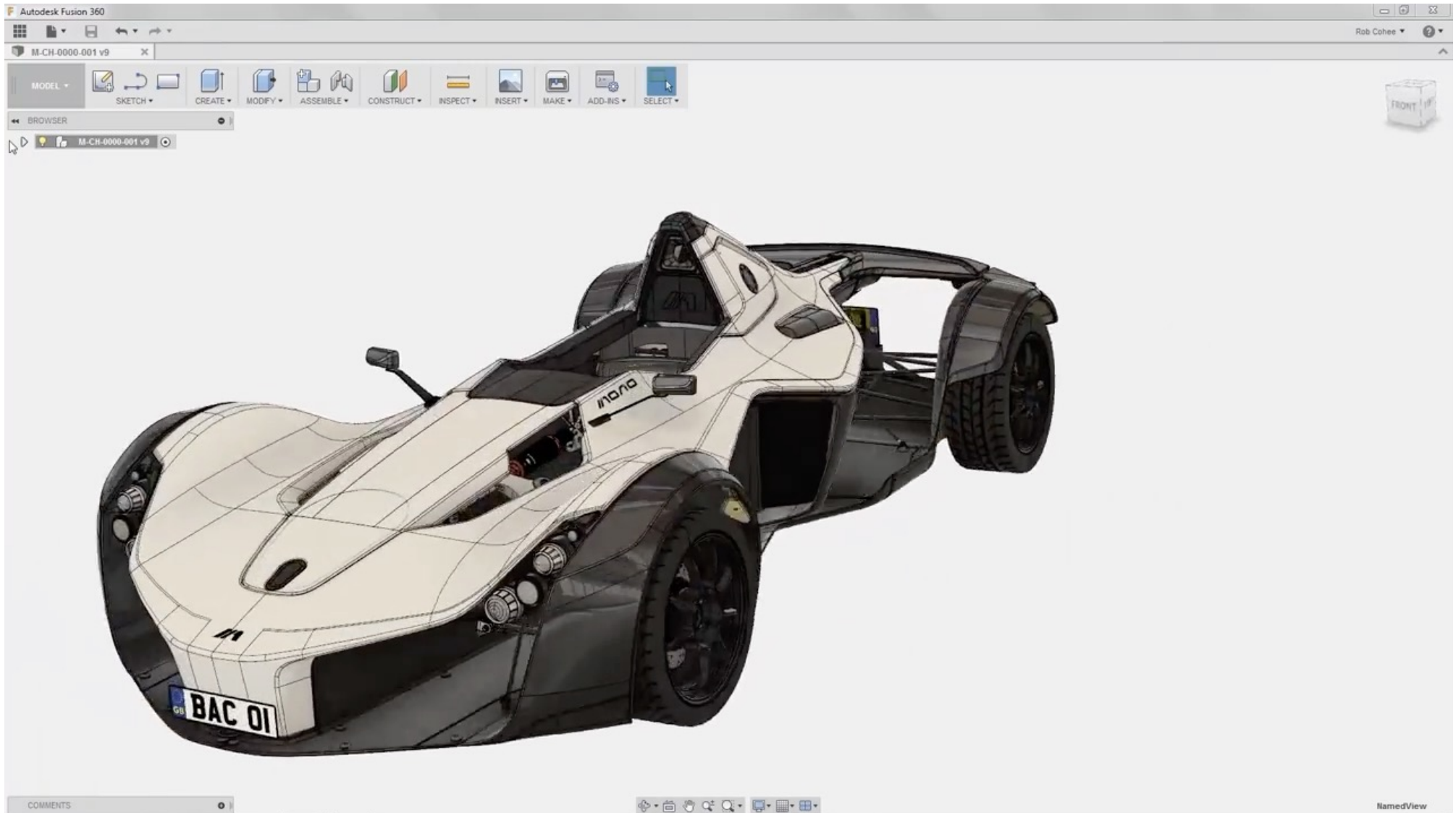



DS323: AI in Design (AIID)

<https://ds323.ancorasir.com/>

Autumn 2023

Thank you~

Wan Fang
Southern University of Science and Technology